

VSC7967

PON Integrated 155 Mbps to 2.5 Gbps Burst-mode Laser Driver and Limiting Amplifier



APPLICATIONS:

- ▶ BPON, GE-PON, and GPON burst-mode laser driver

SPECIFICATIONS:

- ▶ Package size: 5 mm x 5 mm QFN
- ▶ Maximum modulation = 80 mA
- ▶ Typical core power = 330 mW
- ▶ Operating temperature range = -40 °C to 100 °C

FEATURES:

- ▶ APC loop requires no initialization phase
- ▶ VSC7967 meets the specification for BPON, GE-PON, and GPON
- ▶ Burst enable input supports LVPECL, LVDS, and LVTTTL output levels
- ▶ Selectable resistance on monitor diode input
- ▶ Laser driver crossing point control
- ▶ Built-in eye safety support

BENEFITS:

- ▶ Laser driver is ready to transmit upon power up
- ▶ Allows the VSC7967 to be used in both PON and SFP module solutions
- ▶ Allows PON module to interoperate with multiple upstream devices
- ▶ Improves accuracy of the monitor diode input by allowing the user to select the resistance and capacitance in the input
- ▶ Enables the user to adjust the level of the crossing point on the laser driver output
- ▶ No external components are required to meet IEC-60825 eye safety specifications

APPLICATION DIAGRAM:

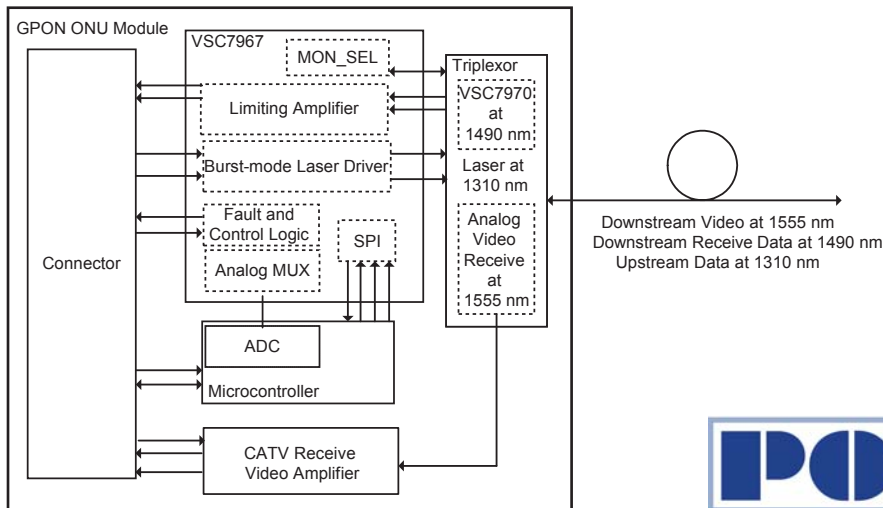

VSC7967

PON Integrated Burst-mode Laser Driver and Limiting Amplifier

GENERAL DESCRIPTION:



The VSC7967 is a multirate 1.25 Gbps integrated laser driver and 2.5 Gbps limiting amplifier for Passive Optical Network applications optimized to reduce module cost. The device is intended to drive distributed feedback (DFB) and Fabry Perot (FP) lasers. A standard SPI port is provided for programming integrated digital-to-analog converters for laser bias current,

modulation current, average power, and the limiting amplifier loss of signal threshold. The VSC7967 is equipped with SFP-compliant fault indicators, redundant disable control, Automatic Power Control, temperature sensor, various signal monitors, and robust eye safety features. The VSC7967 is available in a 5mm x 5mm 32-pin QFN plastic package.

BLOCK DIAGRAMS:

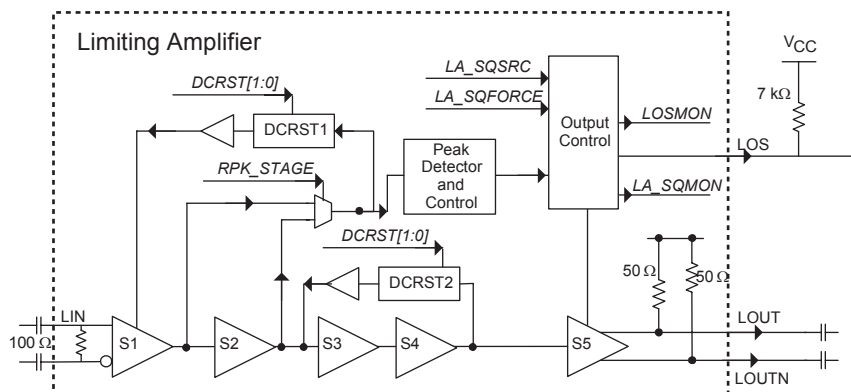
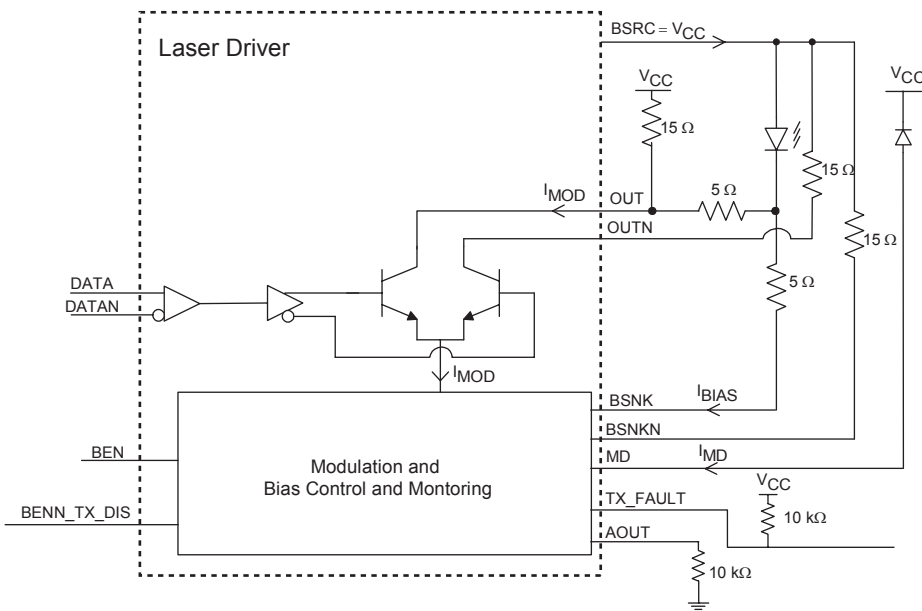

Trademarks™

Vitesse, ASIC-Friendly, FibreTimer, TimeStream, Snoop Loop, Super FEC, FOCUSConnect, Meigs-II, Meigs-III, Lansing, Campbell-I, Barrington, PaceMaker, HOVCAT48, HOVCAT48e, HOVCAT192, HOVCAT192e, Micro PHY, FOCUS32, FOCUS16, IQ2200, NexSAS, VersaCAT, GigaStream, HawX, SparX, StaX, VstaX, SimpliPHY, VeriPHY, ActiPHY, XFP PRO, SFP PRO, Smart-LINK, OctalMAC, EQ Technology are trademarks in the United States and/or other jurisdictions of Vitesse Semiconductor Corporation. All other trademarks or registered trademarks mentioned herein are the property of their respective holders.

Copyright © 2006

Vitesse Semiconductor Corporation ("Vitesse") retains the right to make changes to its products or specifications to improve performance, reliability or manufacturability. All information in this document, including descriptions of features, functions, performance, technical specifications and availability, is subject to change without notice at any time. While the information furnished herein is held to be accurate and reliable, no responsibility will be assumed by Vitesse for its use. Furthermore, the information contained herein does not convey to the purchaser of microelectronic devices any license under the patent right of any manufacturer.

741 Calle Plano
 Camarillo, CA 93012, USA
 Tel: +1 805.388.3700
 Fax: +1 805.987.5896
www.vitesse.com
sales@vitesse.com